

SYNERGY



Full Hosting Service

Synergy has been operating within the SWIFT domain since 1992 and has gained an impressive customer base with an excellent track record for delivering quality services at highly competitive rates.

The company is an accredited SWIFT Service Partner and operates a SWIFT Service Bureau providing over 70 customers with international access to SWIFTNet via its London and Nottingham operations centres. All our customers benefit from resilient and highly secure connections with hassle-free operation and substantial cost savings.

As the SWIFT network continues to evolve, the operational complexities, resource requirements and associated costs will continue to increase.

This trend has resulted in some institutions either centralising their SWIFT operations or seeking the services of a SWIFT Service Bureau to alleviate the expense and the complexities of SWIFTNet changes.

Also, with membership widened to embrace other players such as corporates and the funds industry, the demand for cost-effective and easy access to SWIFTNet has never been higher.

Synergy's SWIFT Service Bureau easily meets this challenge and will appeal to banks, broker dealers, fund managers and corporate treasury departments who demand the highest standards of service delivery whilst experiencing immediate operational and cost benefits.

- Highly secure environment and infrastructure
- Reduce cost
 - Low entry price with full investment protection
 - No in-house connectivity and migration costs
- Hosted in dual active data centres (London & Nottingham)
- Fast Access to business continuity through fail-safe architecture
- Reduce need for in-house SWIFT specific skills
- Integration with host systems with customisable options (Facilitates STP)
- All SWIFT services available (FIN, FileAct, InterAct, Browse etc)



Ready Services

United Kingdom 2010



Synergy's Service Bureau Removes Operational Complexities, Lifts Management Burden and Reduces Costs

At A Glance

- SWIFTNet FIN access for Production, Standby and Disaster Recovery connectivity
- Direct connectivity to the bureau from customer premises
- Thin client deployment
- No installation requirement
- Simple and competent implementation in the shortest time
- No migration or one-off connection charges
- Future SWIFT upgrades included with access to all SWIFT services
- Tailored, specific integration with all conversions and interface connections handled
- Existing back office connectivity maintained using existing interfaces, i.e. FTP, CASmf, MQ Series etc.
- Two annual business continuity tests from customer's DR premises
- Simplified billing for SWIFTNet access
- Established reputation for service excellence
- Comprehensive service level agreement for high availability
- Complete project management for new connections & migrations

Access to a SWIFT interface for your organisation will be required as a result of a solid business decision rooted in your need to access one or more of the following services:

- SWIFTNet CREST
- SWIFTNet FIN
- SWIFTNet FileAct
- SEPA
- TARGET2
- And a whole range of SWIFTNet solutions

Management and operation of a complete SWIFT infrastructure brings additional work-load and a host of operational complexities. These factors are an important consideration in any decisions you make on how best to achieve the required functionality.

Synergy's fully hosted service, where you access SWIFT through a complete SWIFT infrastructure that we maintain and operate in our fully resilient data centres, offers a secure, resilient and extremely cost effective option. Your management overhead and operational work-load are substantially reduced.

With the SWIFT environment bringing new obligations for routine and ad-hoc manual intervention combined with a mandatory requirement to maintain reliable connectivity for the duration of each business day, a fully hosted service will provide a more reliable service at a substantially reduced overall cost.

Synergy's Service Bureau has sufficient scale for us to be able to make all this available at an excellent price – all backed by a comprehensive Service Level Agreement.

The bureau takes care of all your host and manually generated messages via automated file transfer (AFT) and IBM MQ and offers an optional service for message transformation, i.e. converting your proprietary host data to SWIFT message format and vice versa. For manual message entry users can access SWIFTnet via our 'thin-client' application, namely MessageMaker, or by using SWIFTAlliance Messenger.

Synergy has vast experience in

- Supporting SWIFT interface systems
- Developing world-class messaging software solutions
- Managing SWIFT operations
- Creating an effective infrastructure for SWIFTNet connectivity
- SWIFTNet migration support
- Message transformation

All underpinned by a professional and dedicated team providing an acclaimed service to over 70 accounts with SWIFT Service Partner and SWIFT Service Bureau accreditations.

Synergy's Full Hosting Infrastructure

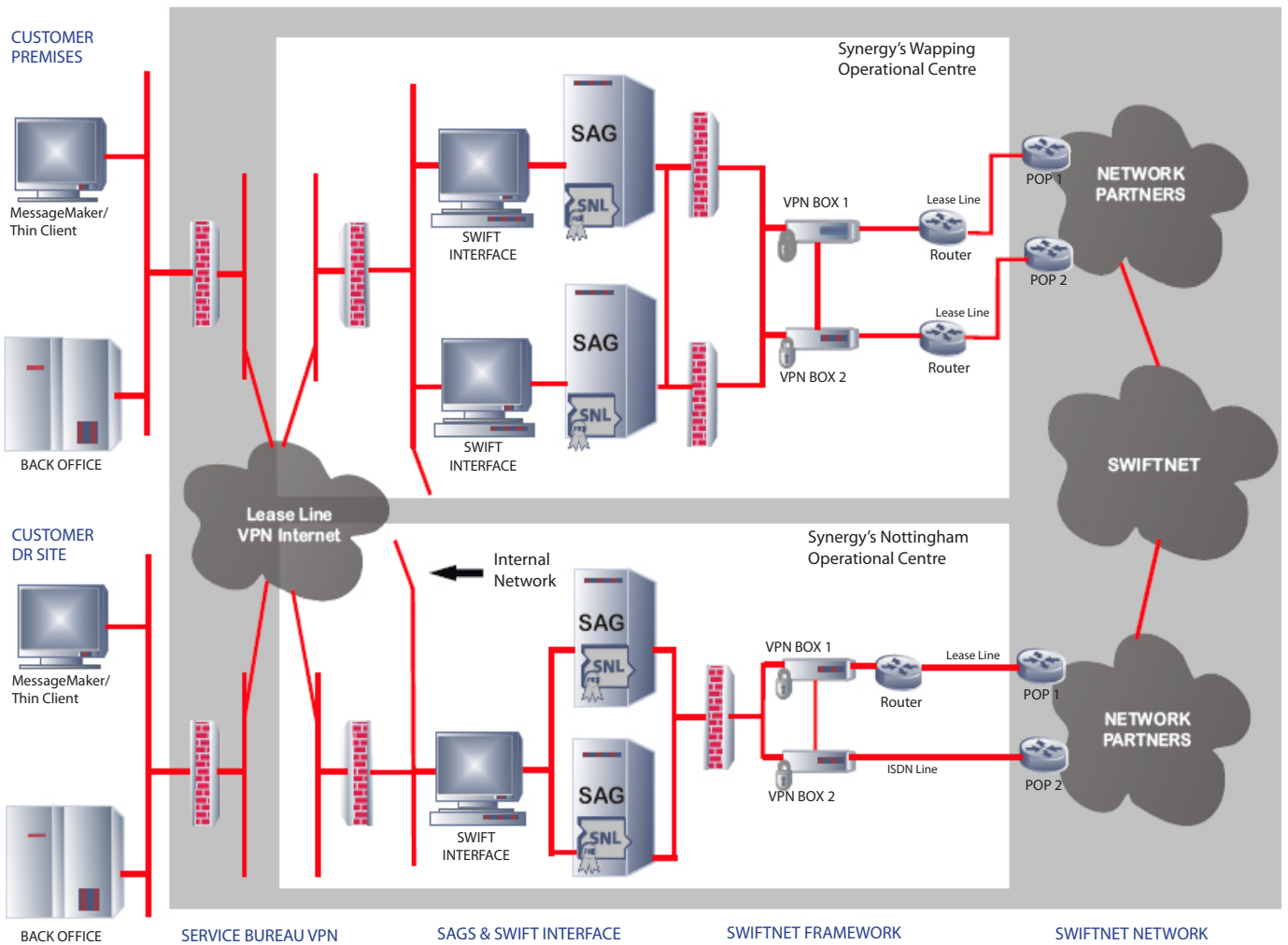

Service Deliverables

SWIFTAlliance Gateway (SAG) & SWIFT Interface

- High specification servers housed in a secure location
- Active standby and remote SAG contingency capability
- Optional access to SWIFTNet services based upon business requirements

SWIFTNet Connectivity

- 128K Dual-P diverse routed access to the SWIFT network
- Firewall protection between SWIFT network and SAG
- Assisted certificate management and renewal, i.e. SNL, SO, AUTH DN

Bureau Connectivity For Production Access

- Managed Lease Line/Internet VPN customer connectivity
- Resilient lease line for automatic fallback contingency
- All Bureau access authenticated using PKI

Bureau Connectivity For Disaster Recovery Access

- Managed Internet VPN customer connectivity
- Optional lease line access
- All Bureau access authenticated using PKI

Data Security & Protection

- Encrypted data transfer from SWIFT Interface, i.e. Alliance Server to SAG
- Encrypted data transfer from SAG to SWIFT network

Network Implementation

- Installation and configuration of network equipment, router and firewall

Service Benefits

- Guaranteed message delivery with resilience, fast access and recovery capability by using a Dual-P SWIFTNet Link connection
- Peace of mind of a managed service
 - SWIFT certified engineers
 - High levels of availability and fast problem resolution
- Fully redundant infrastructure with hot standby servers at the production site, a geographically remote DR site, and a reduction in single points of failure
- Removes the complexity of managing your in-house SWIFTNet environment whilst saving costs on IT and SWIFT specific personnel
- Significantly reduces your costs through an outsourced service using our know-how
- Provides integration and customisable options to suit your business needs
- Retain full control over your applications and financial transactions
- Future proofs access to SWIFTNet services such as FileAct, InterAct, Browse etc.
- Facilitates subscriptions to MA-CUGS via SWIFTNet Browser
- Investment protection for SWIFTNet

Synergy's Implementation Process

- Customer selects connectivity option
- Synergy e-orders SWIFT services and any required network services
- Synergy produces project plan for network integration
- Synergy implements and tests connectivity
- Synergy and Customer schedule go-live date for new service

Choose Synergy's Service Bureau

Cost Saving

Synergy offers a cost-effective environment that reduces management burden and in-house operational complexities whilst saving costs on IT and SWIFT specific personnel. We are careful to make sure that our pricing is transparent with no surprises.

True Resilience

We achieve this by using two data centres, both continually active and located geographically remote from one another. Our network is engineered to ensure that there are no single points of failure and is entrusted to BT Radianz as a network provider. Resilience extends to the human side of the business too with operations conducted from multiple monitoring and control locations.

Experience

Synergy has been operating within the SWIFT domain since 1992. Our engineers are all certificated by SWIFT with an in-depth knowledge of the systems and also have a wealth of experience in supporting SWIFT interface systems as well as managing SWIFT operations. Our engineers are renowned for their effectiveness and customers focus.

Investment Protection

At synergy, we understand that for our customers, their SWIFT infrastructure supports critical business processes. Putting your faith in our Service Bureau will provide you with investment protection. We take full responsibility for maintaining and updating SWIFT infrastructure software and equipment.

Synergy Financial Systems Limited

www.synergy-fs.com

Nottingham Office
Synergy House, Highfields Science Park
University Boulevard, Nottingham, NG7 2RF, UK
Tel: + 44 (0)115 967 7990
Fax: + 44 (0)115 967 7933

London Office
42 New Broad Street
London, EC2M 1SB, UK
Tel: + 44 (0)207 374 6200
E-mail: info@synergy-fs.com