

SYNERGY



SWIFTNet ITB Hosted Service

SWIFT Solution Partners who develop messaging solutions for the SWIFT community are mandated to demonstrate the use of SWIFT's Integration Test Bed (ITB) to successfully send SWIFTNet traffic, i.e. FIN, InterAct and FileAct, especially if an application label is to be granted.

This can require a considerable financial investment in SWIFTNet infrastructure and Solution Partners are particularly conscious of the relatively high costs associated with sending and testing messages to the ITB, particularly if the service is used infrequently!

We offer Solution Partners a low cost SWIFTNet ITB Hosting Service via our Service Bureau. This will provide you with access to the range of SWIFTNet Solutions offered by SWIFT and lets you get on with testing your messages without the burden of managing complex in-house SWIFTNet infrastructure.

Synergy's presence in the SWIFT community, as both a SWIFT Service Partner and SWIFT Service Bureau operator, enables us to provide attractive support, connectivity and hosting services to users of the SWIFT network.

Our SWIFT Service Bureau provides hosted connectivity to a large number of financial institutions and other Solution Partners and is now available to you.

- Dramatically reduces your testing costs
- Eliminates the complexity of your in-house SWIFTNet environment
- You gain significant improvements in resilience, fast access and recovery capability
- Reduces need for in-house SWIFT specific skills
- Integration with host systems with customisable options
- All SWIFTNet ITB services available (FIN, FUNDS, CASH MANAGEMENT, ETC)
- Eliminates the burden of certificate management



Ready Services

United Kingdom 2010



Synergy's Fully Hosted Service for SWIFTNet ITB

- Reduces Operational Impact of Testing
- Simplifies Management
- Reduces Costs

At A Glance

- Connectivity to the bureau from the Solution Partner's premises
- No migration or one-off connection charges
- A single reusable gateway
- Service level agreement for high availability
- Established reputation for service excellence

Our SWIFT Service Bureau provides a hosted service to SWIFTNet ITB for Solution Partners who want to benefit from increased ROI while reducing cost and insulating the company from the frustrations of upgrades and the increasing operational complexities associated with SWIFTNet Phase 2.

Connectivity is via Synergy's SWIFT Alliance Gateway (SAG) and SWIFTAlliance Access (SAA) Server.

Continuous evolution of SWIFTNet has placed a significant cost and resource burden on all SWIFT users and many will seek to outsource their operations to a third party service bureau. Synergy's fully hosted service offers you a resilient and cost-effective environment that removes your management burden and in-house operational complexities. It is supported by a team of SWIFT certified specialists and backed by a comprehensive Service Level Agreement (SLA).

The bureau takes care of all your application(s) and manually generated messages via automated file transfer (AFT). For manual message entry users can access SWIFTnet via our 'thin-client' application, MessageMaker, or by using SWIFTAlliance Messenger.

Synergy's SWIFTNet ITB Hosting Infrastructure

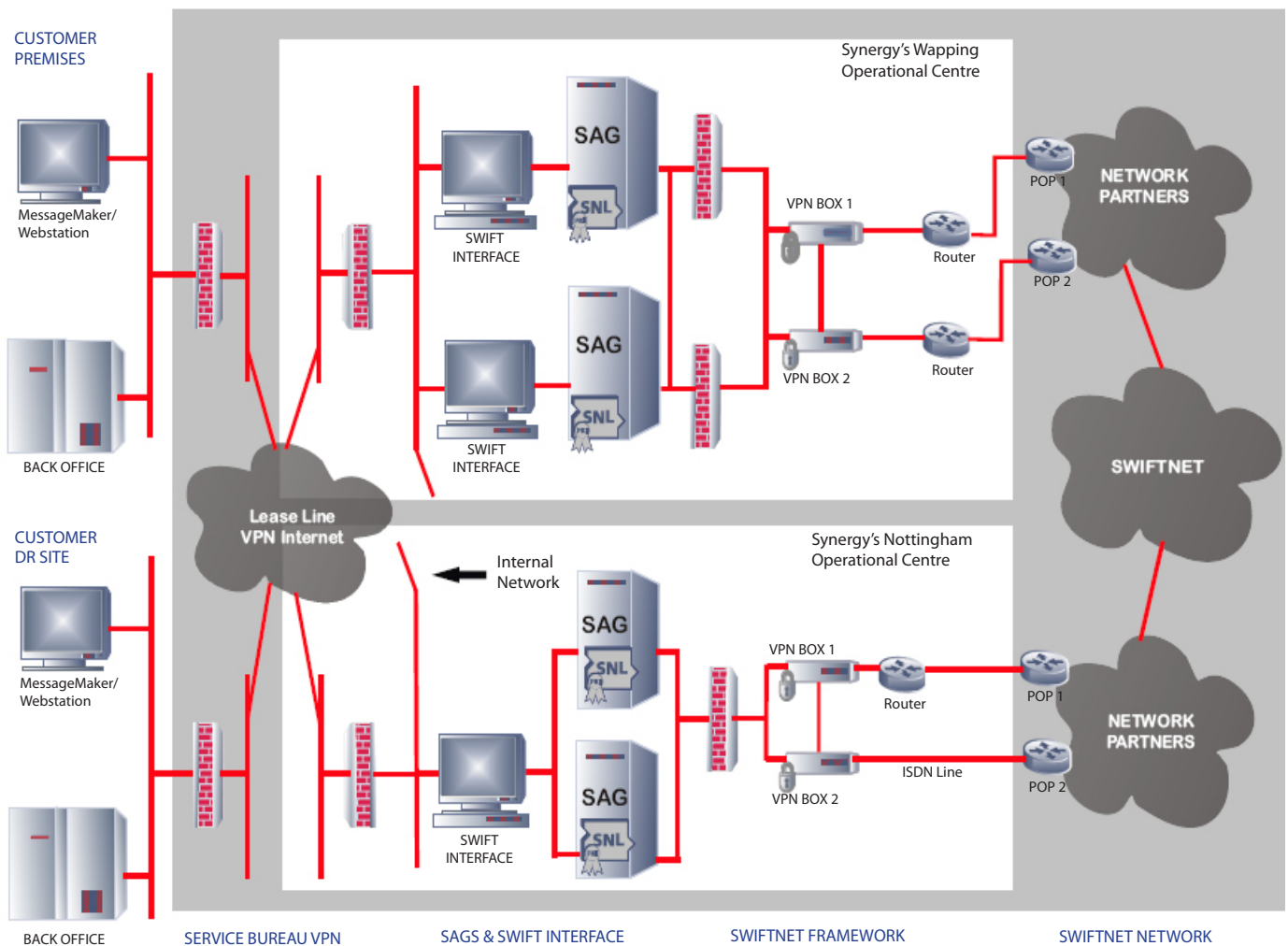

Service Deliverables

SWIFTAlliance Gateway (SAG) & SWIFTAlliance Access

- High specification servers housed in a secure location
- Standby and remote SAG contingency capability
- Access to SWIFTNet ITB services based upon testing requirements

SWIFTNet Connectivity

- Fast Dual-P diverse routed access to the SWIFT network
- Assisted certificate management and renewal, i.e. SNL, SO, AUTH DN

Bureau Connectivity For Solution Partner Access

- Managed Internet VPN connectivity
- Managed Firewalls
- All Bureau access authenticated using PKI

Service Benefits

- Guaranteed test facility with fast access to SWIFTNet ITB
- Managed service with SWIFT Certified Engineers
- Removes the complexity of managing your in-house SWIFTNet environment whilst saving costs on IT and SWIFT specific personnel
- Provides integration and customisable options to suit your testing requirements
- You retain full control over your application(s) testing.
- Provides a fully redundant bureau infrastructure

Choose Synergy's Service Bureau

Cost Saving

Synergy offers a cost-effective environment that reduces management burden and in-house operational complexities whilst saving costs on IT and SWIFT specific personnel. We are careful to make sure that our pricing is transparent with no surprises.

True Resilience

We achieve this by using two data centres, both continually active and located geographically remote from one another. Our network is engineered to ensure that there are no single points of failure and is entrusted to BT Radianz as a network provider. Resilience extends to the human side of the business too with operations conducted from multiple monitoring and control locations.

Experience

Synergy has been operating within the SWIFT domain since 1992. Our engineers are all certificated by SWIFT with an in-depth knowledge of the systems and also have a wealth of experience in supporting SWIFT interface systems as well as managing SWIFT operations. Our engineers are renowned for their effectiveness and customers focus.

Investment protection

At synergy, we understand that for our customers, their SWIFT infrastructure supports critical business processes. Putting your faith in our Service Bureau will provide you with investment protection. We take full responsibility for maintaining and updating SWIFT infrastructure software and equipment.

Synergy Financial Systems Limited

www.synergy-fs.com

Nottingham Office
Synergy House, Highfields Science Park
University Boulevard, Nottingham, NG7 2RF, UK
Tel: + 44 (0)115 967 7990
Fax: + 44 (0)115 967 7933

London Office
42 New Broad Street
London, EC2M 1SB, UK
Tel: + 44 (0)207 374 6200
E-mail: info@synergy-fs.com