

SYNERGY



SWIFTNet ITB Connectivity Service

SWIFT Solution Partners who develop messaging solutions for the SWIFT community are mandated to demonstrate the use of SWIFT's Integration Test Bed (ITB) to successfully send SWIFTNet traffic, i.e. InterAct and FileAct, especially if an application label is to be granted.

This can result in a considerable financial investment in SWIFTNet infrastructure. Solution Partners are particularly conscious of the relatively high costs associated with sending and testing messages to the ITB, particularly if the service is used infrequently.

We offer Solution Partners a low cost SWIFTNet ITB connectivity option via our SWIFT Service Bureau. This will provide you with access to the range of SWIFTNet Solutions offered by SWIFT. You can get on with testing your messages without the burden of managing complex SNL connectivity.

Synergy's presence in the SWIFT community, as both a SWIFT Service Partner and SWIFT Service Bureau operator, enables us to provide attractive support and connectivity services to users of the SWIFT network.

Our SWIFT Service Bureau provides hosted connectivity to a large number of financial institutions and other Solution Partners and is now available to you.

- Dramatically reduces your connectivity costs
- Reduces the complexity of your SWIFTNet environment
- You gain significant improvements in resilience, fast access and recovery capability
- Replaces dial-up access with lease line connectivity via the bureau
- Measured and controlled Alliance connectivity for Integration Test Bed operation
- Eliminate the burden of certificate management
- Investment protection as SWIFTNet continues to evolve



Ready Services

United Kingdom 2010

Synergy's SWIFTNet ITB Connectivity Infrastructure

The SWIFT Alliance Gateway (SAG), which simplifies SNL connectivity for SWIFT Alliance Access interfaces, is the basis for Synergy's SWIFTNet ITB Connectivity Service and is an ideal solution for SWIFT Solutions Partners who do not have an ITB/VTB environment, or for those who operate dial-up access, SINGLE-I or DUAL-I and require the ability to enhance their SWIFTNet ITB/VTB testing capability.

It provides the test framework for developing new SWIFTNet Solutions, cuts out the expense of purchasing SAG hardware and simplifies the operation of SWIFTNet for Alliance and SAG.

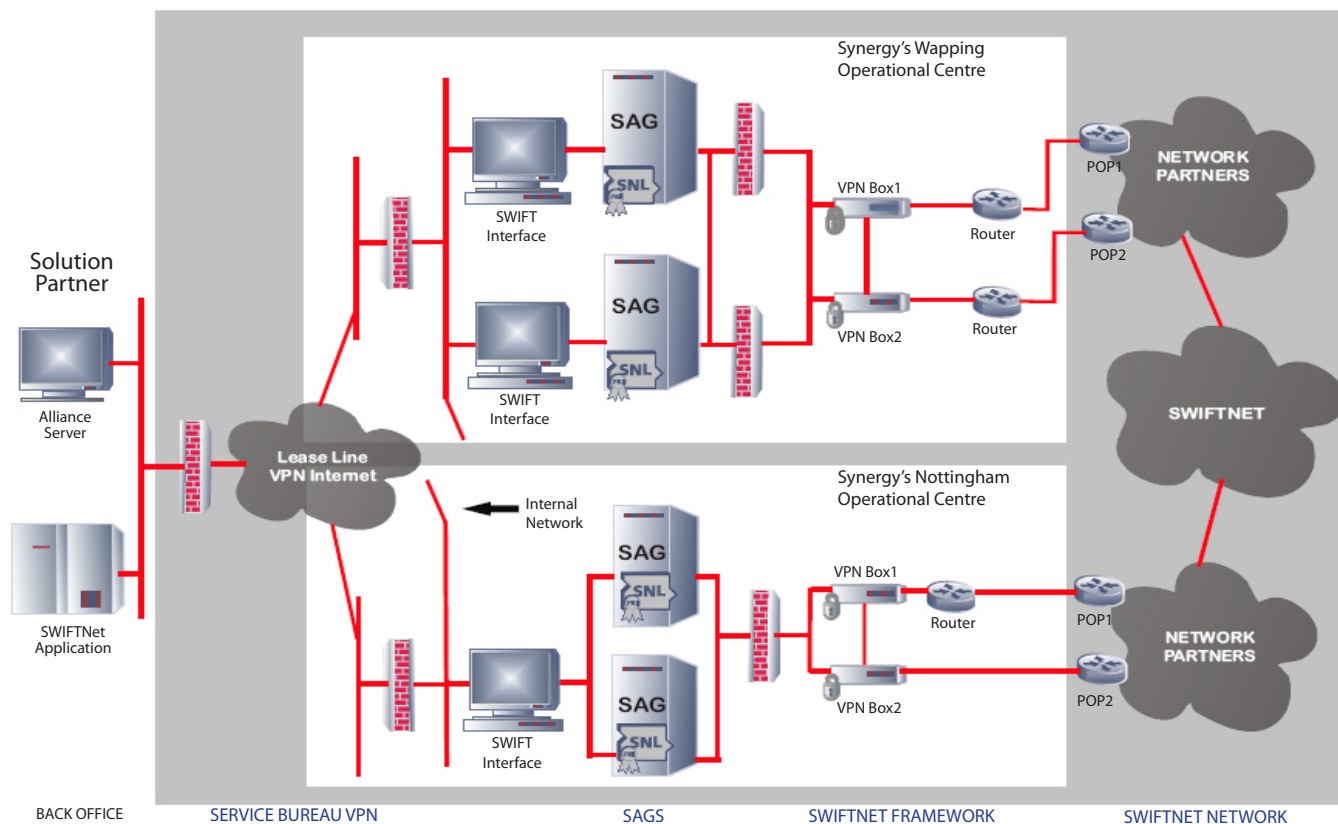

Service Features

SWIFT Alliance Gateway (SAG)

- High specification servers housed in a secure location
- Access via RAHA, MQHA and SWIFTNet Browse
- Subscription and access to SWIFTNet Solution Services

SWIFTNet Connectivity

- 128K Dual-P diverse routed access to the SWIFT network
- Firewall connectivity between SWIFT network and SAG
- Assisted certificate management and renewal
i.e. SNL, SO, AUTH DN

Bureau Connectivity for Integrated Test Bed (ITB) Access

- VPN customer connectivity
- Internet VPN Access
- All Bureau access authenticated using PKI

Data Protection

- Encrypted data transfer from SWIFT Interface, i.e. Alliance Server to SAG
- Encrypted data transfer from SAG to SWIFT network

SWIFTNet Integration

- SAG Remote API access on SWIFT Interface, i.e. Alliance
- SAG Remote API access for Solution Partner Product
- Installation and configuration of network equipment, router and Firewall

Synergy Financial Systems Limited

Nottingham Office
Synergy House, Highfields Science Park
University Boulevard, Nottingham, NG7 2RF, UK
Tel: + 44 (0)115 967 7990
Fax: + 44 (0)115 967 7933

www.synergy-fs.com

London Office
42 New Broad Street
London, EC2M 1SB, UK
Tel: + 44 (0)207 374 6200
E-mail: info@synergy-fs.com