

SYNERGY



DR Connectivity Service

Is Your SWIFT DR Strategy Becoming A Headache?

Setting up, testing and invoking a SWIFTNet DR environment has always been a bit of a headache for some financial institutions. As the SWIFT continues to evolve, the operational complexities, resource requirements and associated costs will continue to increase.

Synergy's hosted connectivity service for SWIFTNet DR provides the ideal relief for institutions who want to remove this headache altogether.

If you are reviewing your SWIFTNet DR requirements, we would be delighted to provide you with a proposal outlining deliverables and costs.

There are no set-up costs for the service. Subscription to the bureau is extremely reasonable with straightforward implementation.

Synergy's SWIFT Service Bureau manages hosted access to the SWIFT network more than 70 institutions and is well placed to provide additional connectivity services for institutions needing a secure and resilient yet cost-effective DR capability.

Your SWIFTNet DR Plan is based on our SWIFT Alliance Gateway (SAG) interface which simplifies SNL connectivity to SWIFT's Alliance Access/Entry interface systems.

Our SAG eliminates the need for Alliance users to invest in localised DR VPN boxes whether attached to dial-up or leased lines provided by SWIFT's Network Partners. Your SWIFTNet security certificates will be managed by us and you will have access to SWIFTNet for either testing or fail-over, at any time.

We are offering you a DUAL-P (Wapping) and Dual-I (Nottingham) SNL connection at Synergy's SWIFT Service Bureau. This will also provide you with an opportunity to subscribe to other DR SWIFTNet services such as Cash Management Reporting etc., should these be required.



Ready Services

United Kingdom 2010

Synergy's SWIFTNet DR Connectivity Infrastructure

The schematic below shows two connectivity options; a) a secure Internet VPN connection for customers who require SWIFTNet DR access if their direct SWIFTNet connection fails, and b) connectivity via BTRadianz from the customer's DR Provider's site (subject to BTRadianz availability at the DR site).

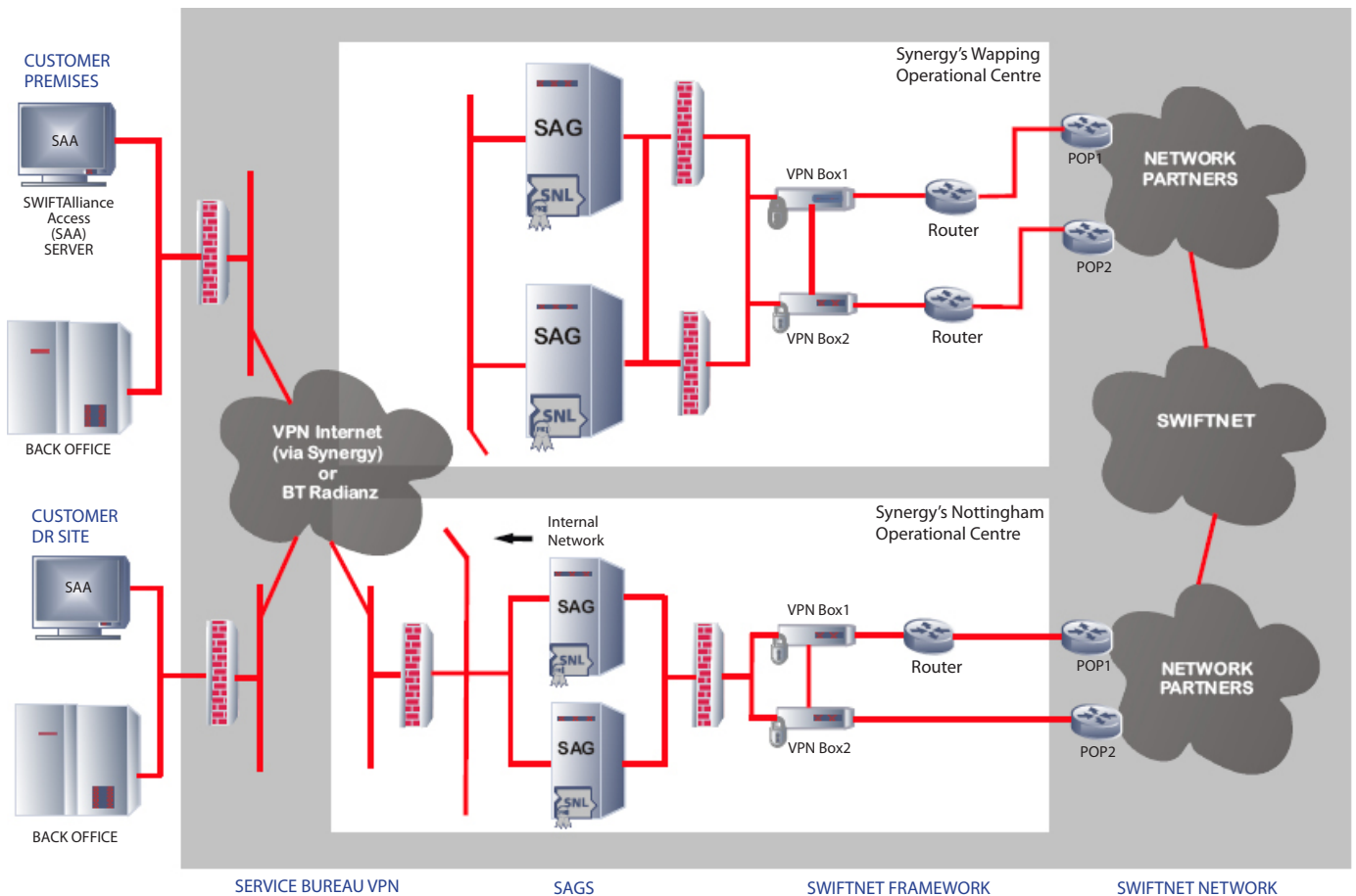

Service Features

- Connectivity to Synergy's SNL Hosting Service from your DR premises
- Multiple access points to the SWIFT network (Dual-P from Wapping and Dual-I from Nottingham)
- Expensive SWIFTNet connectivity can be replaced with inexpensive BTRadianz lease line connectivity
- Reduced complexity at the customer's DR premises (no SNL or SAG software to recover)
- No impact on existing production environment
- No migration or one-off connection charges
- Customer certificates securely stored at Synergy's operations centres
- Multiple SAG environments available for enhanced service availability
- High availability service 24 x 7 (excluding SWIFT Allowed Downtime Window)
- SAG upgrades and customer RA software undertaken as part of the service

Synergy Financial Systems Limited

Nottingham Office
 Synergy House, Highfields Science Park
 University Boulevard, Nottingham, NG7 2RF, UK
 Tel: + 44 (0)115 967 7990
 Fax: + 44 (0)115 967 7933

www.synergy-fs.com

London Office
 42 New Broad Street
 London, EC2M 1SB, UK
 Tel: + 44 (0)207 374 6200
 E-mail: info@synergy-fs.com