

SYNERGY



## SWIFTNet Connectivity Service

Simplifying SWIFTNet Connectivity, Eliminating Operational Complexity and Reducing Costs

- Reduces the complexity of your SWIFTNet environment
- Excellent return on investment with a host of operational advantages by using Synergy's SAG
- Protects your investment
- Offers significant improvements in resilience, fast access and recovery capability
- Eliminates the burden of certificate management
- Non material outsourcing
- Compatible with all SWIFT Interface providers, TurboSwift, MINT etc.
- Provides access to a number of SWIFTNet solutions or services
  - SWIFTNet CREST
  - SWIFTNet FIN
  - SWIFTNet FileAct
  - SEPA
  - TARGET2
  - And a whole range of SWIFTNet solutions



*Ready Services*

United Kingdom 2010



## Synergy's Service Bureau Simplifies SWIFTNet Connectivity, Eliminates Operational Complexity and Reduces Costs

Existing or proposed SWIFTNet connectivity for your organisation will be rooted in your need to access one or more of the following SWIFT services:

- SWIFTNet CREST
- SWIFTNet FIN
- SWIFTNet FileAct
- SEPA
- TARGET2
- And a whole range of SWIFTNet solutions

In planning or reviewing your implementation, you need to consider the cost, complexity and hassle associated with managing a SWIFT connection internally – especially if you do not already have staff with experience of managing a SWIFTNet connection.

Your existing IT management ethos (in-house, partially out-sourced or fully out-sourced) will also be a significant factor. Whatever your existing infrastructure, the cost, complexity, management overhead and learning curve required to manage a SWIFTNet connection can be daunting for organisations of all sizes.

Synergy's Service Bureau specialises in providing a service that is resilient and managed by a team with years of SWIFT accredited experience. And, because none of your data is persisted on our servers, no material outsourcing is involved.

We leave you to concentrate on managing and operating your SWIFT Interface. Synergy will take care of managing your connection. You therefore avoid the hassle of annual SWIFTNet upgrades. And you will know who to call if you need support. You will also have the peace of mind that comes with two (included) business continuity tests as well as unlimited support from Synergy SWIFTNet consultants.

SWIFT Alliance Gateway (SAG), which simplifies SNL connectivity for SWIFT's Alliance Access and Entry interfaces, is the basis for Synergy's SNL Hosting Services.

This therefore eliminates the need for Alliance users to invest in localised VPN boxes, whether attached to dial-up or lease lines provided by Network Partners.

The standard connectivity offered via the SNL Hosting Services is via a DUAL-P connection at Synergy's bureau.

Furthermore, the SAG connection allows the Alliance user to participate in the subscription to additional SWIFTNet services, i.e. Cash Management Reporting, when business requirements require.

Customers wanting to upgrade from a dial-up connection to lease line access can subscribe to Synergy's SWIFTNet Connectivity Services at a cost which is comparable to that of their existing implementation, without having to incur the large increase in costs associated with a DUAL-I connection.

### At A Glance

- SWIFTNet FIN access for Alliance Production, Standby and Disaster Recovery connectivity
- Connectivity to the bureau from the customer premises
- A 30% cost reduction in comparison to Dual-I connectivity and equivalent costs for dial-up
- No migration or one-off connection charges
- A single reusable gateway
- Comprehensive service level agreement for high availability
- Complete project management for new connection/migrations
- Two annual business continuity tests from customer's DR premises
- Simplified semi annual billing for SWIFTNet access
- Investment protection for SWIFTNet Phase II

# Synergy's SWIFTNet Connectivity Bureau Infrastructure

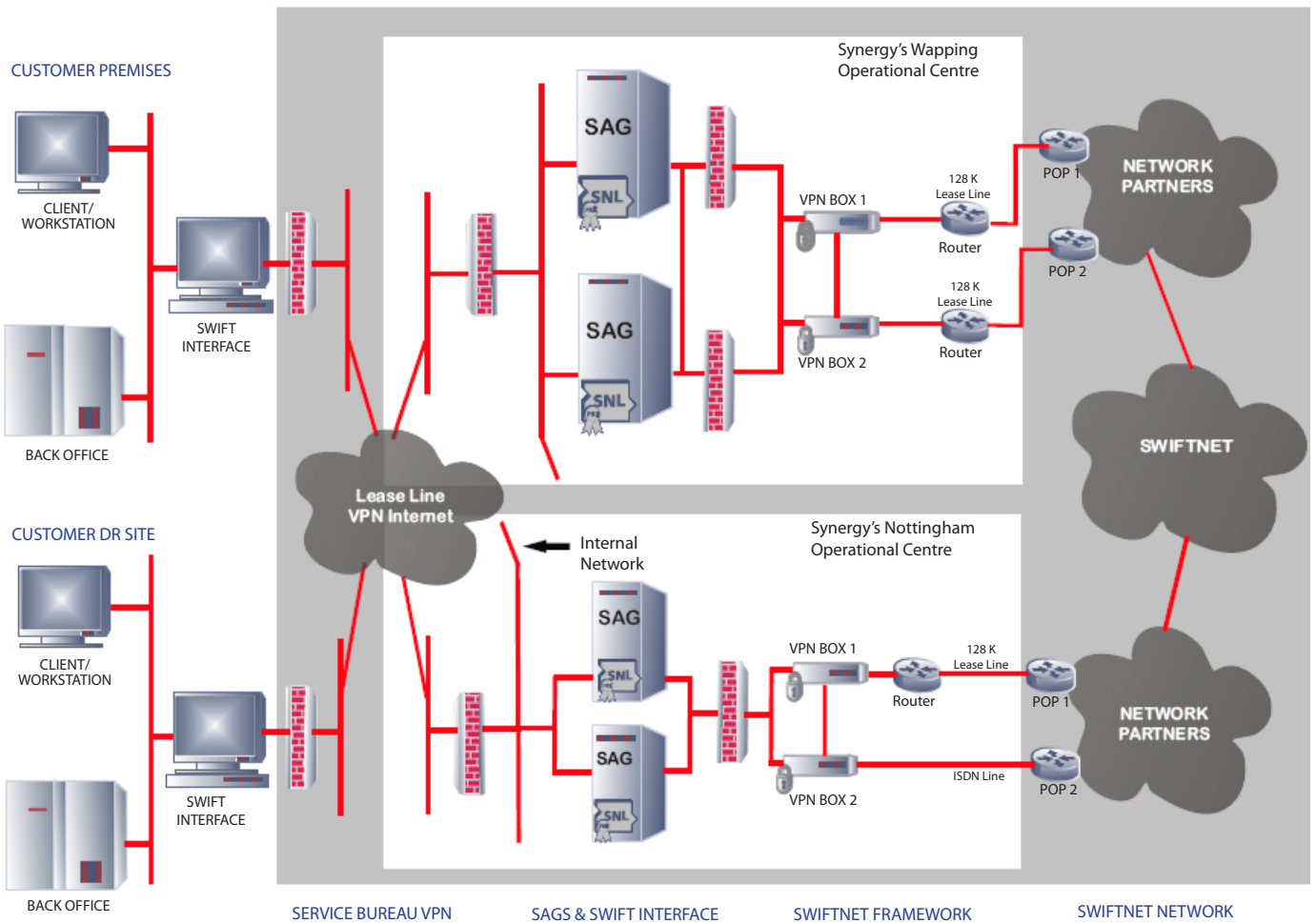

## Service Deliverables

### SWIFTAlliance Gateway (SAG)

- High specification servers housed in a secure location
- Standby and remote SAG contingency capability
- Optional access to SWIFTNet services based upon business requirements

### SWIFTNet Connectivity

- Fast Dual-P diverse routed access to the SWIFT network
- Firewall protection between SWIFT network and SAG
- Certificate management and renewal, i.e. SNL, SO, AUTH DN

### Bureau Connectivity For Production Access

- Managed VPN customer connectivity
- Secure & resilient 64k lease line for automatic fallback contingency
- All bureau access authenticated using PKI

### Bureau Connectivity For Disaster Recovery Access

- Choice of VPN customer connectivity options for remote recovery secure & resilient 64K lease line
  - 2MB ADSL access
  - ISDN/PSTN connectivity
- All Bureau access authenticated using PKI

### Data Security & Protection

- Encrypted data transfer from SWIFT Interface, i.e. Alliance Server to SAG
- Encrypted data transfer from SAG to SWIFT network
- All Bureau access authenticated using PKI

### SWIFT MIS

- Synergy's 'ClarityInfo', browser-based management information system for SWIFTNet & FIN messages
  - Message investigations
  - Archiving
  - Traffic reconciliation

## Service Benefits

- Gain significant improvements in resilience, fast access and recovery capability by using a 128Kbit Dual-P SWIFTNet Link connection
- Cost-effective migrations from dial-up SWIFT access to resilient lease line connectivity via the bureau
- Cut out downtime exposure and provide a framework for measured and controlled Alliance connectivity for both production and disaster recovery operation
- Reduce the complexity of the customers' SWIFTNet FIN configuration
- Protect the investment made in existing SWIFT infrastructure and maintaining the customer's system at the customer's premises
- Remove the need for customers to subscribe to expensive lease line options (SINGLE-I and DUAL-I)
- Centralise certificate management and eliminate management burden
- Enable access to SWIFTNet services (FileAct, InterAct, Browse) via a centralised SWIFT Alliance Gateway (SAG) in Synergy's data centre
- Facilitate subscriptions to MA-CUGS via SWIFTNet Browse
- Investment protection for SWIFTNet Phase II

## Synergy's Implementation Process

- Customer selects connectivity option
- Synergy e-orders SWIFT services and any required network services
- Synergy produces project plan for network integration
- Synergy implements and tests connectivity
- Synergy and Customer schedule go-live date for new service

## Choose Synergy's Service Bureau

### Cost Saving

Synergy offers a cost-effective environment that reduces management burden and in-house operational complexities whilst saving costs on IT and SWIFT specific personnel. We are careful to make sure that our pricing is transparent with no surprises.

### True Resilience

We achieve this by using two data centres, both continually active and located geographically remote from one another. Our network is engineered to ensure that there are no single points of failure and is entrusted to BT Radianz as a network provider. Resilience extends to the human side of the business too with operations conducted from multiple monitoring and control locations.

### Experience

Synergy has been operating within the SWIFT domain since 1992. Our engineers are all certificated by SWIFT with an in-depth knowledge of the systems and also have a wealth of experience in supporting SWIFT interface systems as well as managing SWIFT operations. Our engineers are renowned for their effectiveness and customers focus.

### Investment protection

At synergy, we understand that for our customers, their SWIFT infrastructure supports critical business processes. Putting your faith in our Service Bureau will provide you with investment protection. We take full responsibility for maintaining and updating SWIFT infrastrucuture software and equipment.

Synergy Financial Systems Limited

Nottingham Office  
Synergy House, Highfields Science Park  
University Boulevard, Nottingham, NG7 2RF, UK  
Tel: + 44 (0)115 967 7990  
Fax: + 44 (0)115 967 7933

[www.synergy-fs.com](http://www.synergy-fs.com)

London Office  
42 New Broad Street  
London, EC2M 1SB, UK  
Tel: + 44 (0)207 374 6200  
E-mail: [info@synergy-fs.com](mailto:info@synergy-fs.com)