

SYNERGY



DR Hosting Service

How Effective Is Your SWIFTNet Contingency If Your SWIFT Server Is Based Overseas?

If your branch has access to SWIFTNet via a remote and centralised server, probably located overseas, then this may appeal to you.

As the SWIFT network continues to evolve, the operational complexities, resource requirements and associated costs will continue to increase.

As a result, many overseas branches now have 'thin client' connections to centralised servers accessing SWIFTNet with little or no control of their own local SWIFT operation.

SWIFTNet contingency or DR has, in most cases, been centralised too. This could become problematical for the branch if invocation proved to be difficult, possibly due to compromised communications resulting from political, geographic or other physical limitations.

For this reason, we have developed a special solution that addresses this issue. The solution, known as SWIFTNet DR Connectivity, delivers instant access to SWIFT in the event of an outage or failure at head office, or if the DR server is difficult to access.

SWIFTNet DR Connectivity uses Synergy's SWIFTAlliance Access platform in the bureau where the customer's branch BIC would be registered. The branch would simply use its SWIFTAlliance Messenger for browser log-on to Alliance in the bureau via our secure internet VPN connection to process its incoming and outgoing messages.

There are no set-up costs for the service and subscription to the bureau is extremely reasonable with an easy and hassle-free implementation.

Synergy's SWIFT Service Bureau manages hosted access to the SWIFT network for around 70 institutions and is well placed to provide additional connectivity services for institutions needing a secure and resilient yet cost-effective DR capability.



Ready Services

United Kingdom 2010

Synergy's SWIFTAlliance DR Hosting Infrastructure

The diagram below shows a customer using the bureau for SWIFTNet DR. In this case the customer is a branch of an international bank who uses SWIFTAlliance Messenger (SAM) to access SWIFTNet via a remotely located server, probably overseas.

The schematic shows SAM client at the branch used to access Synergy's bureau via Internet VPN for contingency access to SWIFT. In this case Synergy will register the customer's BIC to its SWIFTAlliance Access.

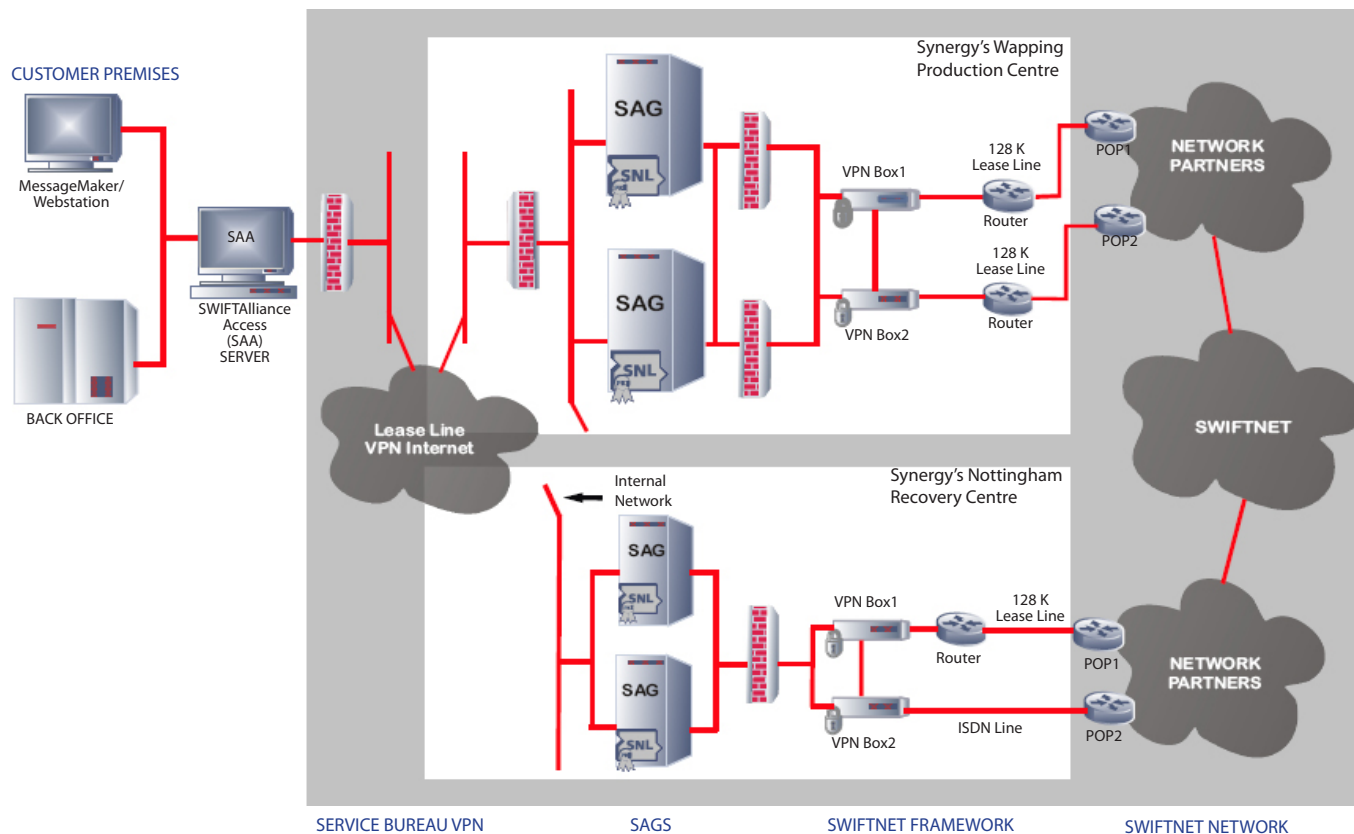

Service Features

- Connectivity to Synergy's SWIFTNet DR Hosting Service from your desktop
- Multiple access points to the SWIFT network (Dual-P from Wapping and Dual-I from Nottingham)
- Expensive SWIFTNet connectivity can be replaced with inexpensive Internet VPN connectivity
- Instant recovery if remote (overseas) DR server is inaccessible
- No impact on existing production environment
- No migration or one-off connection charges
- Customer certificates are securely stored at Synergy's operation centres
- Multiple SAG environments available for enhanced service availability
- High availability service 24 x 7 (excluding SWIFT Allowed Downtime Window)
- SAG upgrades and customer RA software undertaken as part of the service
- Access from anywhere via secure internet VPN

Synergy Financial Systems Limited

Nottingham Office
 Synergy House, Highfields Science Park
 University Boulevard, Nottingham, NG7 2RF, UK
 Tel: + 44 (0)115 967 7990
 Fax: + 44 (0)115 967 7933

www.synergy-fs.com

London Office
 42 New Broad Street
 London, EC2M 1SB, UK
 Tel: + 44 (0)207 374 6200
 E-mail: info@synergy-fs.com